

## SECTION II INSTALLATION

### 2.1. UNPACKING.

2.1.1. PROCEDURE. - Collins 51J-4 receiving equipment is packed in a number of heavy cartons. Refer to the packing slip for a list of all equipment supplied on the order. Open cartons carefully to avoid damaging the contents. Remove the packing material, and carefully lift the units out of the cartons. Search all packing material for small parcels. Extra pilot light bulbs and fuses are supplied with each equipment. Inspect each unit for loose screws and bolts. Make sure that all controls such as switches and dials work properly. All claims for damage should be filed promptly with the transportation company. If a claim is to be filed, the original packing case and material must be preserved.

### 2.2. INSTALLATION.

2.2.1. GENERAL. - The receiver should be mounted in a standard rack. Outline and mounting dimensions are given in figure 2-1. The front panel is slotted for mounting at 1-1/2, 3-3/4, 6-3/4 and 9 inches from the bottom. Panel height is 10-1/2 inches and panel width is 19 inches.

When choosing a position for the receiver, give consideration to convenience of power, antenna and ground connections, to placement of cables and to convenience in servicing the equipment. Rear panel connections are shown in figure 2-2.

2.2.2. ANTENNA CONNECTION. - Connect a cable from a high impedance whip or a single-ended antenna to antenna jack J101 on rear panel. If the receiver is to be operated near a powerful transmitter, the r-f input circuit should be protected by connecting break-in relay K101 to operate when the transmitter is radiating. Break-in relay connections are described in paragraph 2.2.5. below.

2.2.3. AUDIO OUTPUT CONNECTIONS. - Two audio output jacks are located on the front panel. One is designated PHONES and the other SPEAKER, their output impedances being 4 and 600 ohms respectively. An audio output terminal strip is provided on the rear panel. Terminal G is a ground

connection and terminals 4 and 600 are audio outputs of 4 and 600 ohms impedance respectively. Terminal 4 is connected in parallel with the PHONES jack, and terminal 600 is connected in parallel with the SPEAKER jack. Use these output jacks and terminals as required.

2.2.4. I-F OUTPUT CONNECTION. - A 100-200 millivolt, 50 ohm 500 kc i-f output is available at coaxial jack J104 on the rear panel.

2.2.5. REMOTE STANDBY CONNECTIONS. - Break-in relay connections are available at terminal strip E101 at the rear of the chassis. Terminals are marked 1, 2 and 3. Terminal 1 is connected to receiver ground. Terminals 2 and 3 are connected to the break-in relay coil, which is rated at 12 v d-c nominal and 135 ohms d-c resistance. During operation, terminals 2 and 3 are usually connected in series with a source of voltage and a set of normally open contacts on the carrier control relay of a transmitter in order to silence the receiver during transmission. When the break-in relay coil is energized, one pair of contacts shorts the antenna to ground; another pair, connected in series with a section of the OFF-STANDBY-ON switch, removes plate voltage from the three i-f amplifier stages. In STANDBY position, the OFF-STANDBY-ON switch also removes plate voltage from the i-f stages. See figure 2-3.

2.2.6. POWER CONNECTION. - Make power connection by using the rubber - covered cord that is permanently attached at the rear of the chassis. This cord is six feet long and is equipped with a standard a-c plug. The power source must supply 85 watts at 115 volts, 45/70 cps. If 230 volt operation is desired, reconnect transformer T108 by removing the jumpers between terminals 2 and 4 and between 1 and 3; then connect a jumper between terminals 2 and 3.

2.2.7. TUBES. - Before turning on the equipment for the first time inspect the tubes. Be sure that they are in their correct positions, and that they are firmly seated in their sockets.



Section 2  
 INSTALLATION

2.2.8. FUSE. - The fuse is located on the rear of the chassis. It can be removed for inspection by turning the cap of the fuse post to the left and pulling

straight up until the cap and fuse come free. This fuse should be the slow-blow type, with a rating of 1.5 amperes.

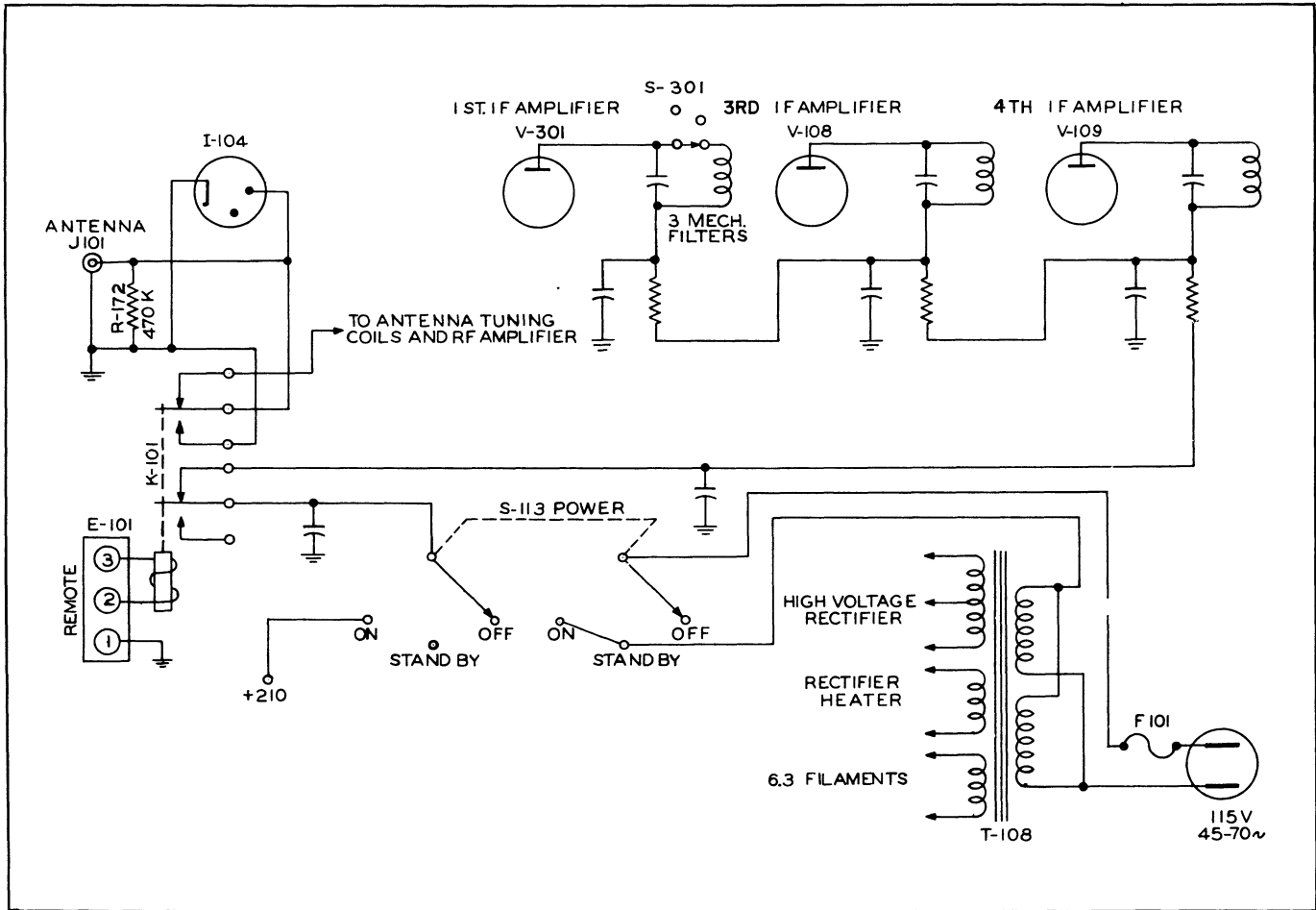

Figure 2-3. 51J-4 On-Off-Standby Functions and Remote Operation Relay Circuit

## SECTION III ADJUSTMENT AND OPERATION

### 3.1. ADJUSTMENT.

3.1.1. GENERAL. - Other than zeroing the S meter no preoperational adjustments are necessary. Should the S meter require zeroing, turn the receiver ON, BFO OFF, AVC ON, and the 100 KC CRYSTAL OFF; then turn the RF GAIN fully clockwise. Short the antenna terminals; then turn the meter zeroing control until the S meter reads zero. Refer to figure 5-1 for location of this control.

### 3.2. OPERATION.

3.2.1. FUNCTION OF CONTROLS. - Operation of the 51J-4 Receiver is exceedingly simple if the functioning of the controls is understood. The following paragraphs explain the functions of the controls on the receiver's front panel.

(a) OFF-STANDBY-ON. - In the OFF position, this control opens the primary power circuit to turn the equipment completely off. In the STANDBY position the power transformer is excited, thus producing filament voltage for all stages and plate voltage for all except three i-f amplifier stages. In the ON position the receiver is completely operative.

(b) RF GAIN. - The RF GAIN control is located in the grid return circuit of the avc controlled tubes and is operative at all times. It varies the amount of fixed bias placed upon the grids of these tubes.

(c) AUDIO GAIN. - The AUDIO GAIN control is located in the grid circuit of the first audio amplifier and is operative at all times. It varies the amount of a-f signal applied to the grid of this tube, and thereby controls the amount of audio power produced by the receiver.

(d) BAND CHANGE. - Any one of the 30 bands may be selected by 1/2 revolution intervals by means of this knob. A stiff detent accurately positions the controlled switches on each band.

(e) MEGACYCLE. - The MEGACYCLE scale is on the slide-rule type dial. It is calibrated in ten 100 kc divisions, each of which equals one full turn

of the circular KILOCYCLE dial. The 1.5 to 2.5 mc and 2.5 to 3.5 mc bands are printed in red, indicating that the red scale on the KILOCYCLE dial must be used when operating on these bands. The pointer on the MEGACYCLE dial is operated by the KILOCYCLE control while the scale is changed by operation of the BAND CHANGE control.

(f) KILOCYCLE. - The KILOCYCLE dial is the main tuning control on the 51J-4 receiver. Each division on its circular face represents one kilocycle. One full turn of the dial tunes the receiver through 100 kilocycles, or one division of the MEGACYCLE scale. To read the tuning dials, merely combine the figures of the MEGACYCLE dial with those of the KILOCYCLE dial, thus arriving at the frequency in kilocycles. For example, a reading of 14.1 on the MEGACYCLE dial and of 78 on the KILOCYCLE dial indicates a frequency of 14178 kc. The KILOCYCLE scale for the 1.5 to 2.5 and 2.5 to 3.5 mc bands is in reverse order to the scale for the rest of the bands, and is printed in red similar to corresponding scales on the MEGACYCLE dial.

(g) ZERO ADJ. - The ZERO ADJ moves the indicator line on the KILOCYCLE control a few divisions in either direction for calibration purposes. The receiver may be calibrated against either any receivable station whose frequency is known or the internal calibration oscillator. This oscillator emits a harmonic every 100 kc in the tuning spectrum. An example of how the receiver may be calibrated using this oscillator follows. If the desired signal is about 14100 kc, turn the 100 KC CRYSTAL ON and the BFO ON with BFO PITCH control at panel mark. Next, using the KILOCYCLE knob, tune to zero beat with the 100 kc marker at 14100 kc. Then move the ZERO ADJ control until the hair line is exactly on 14100 kc. The dial reading in this region is now very accurate, and the receiver may be set within a few hundred cycles of the desired frequency.

A ten division scale (five divisions either side of center) is engraved on the lower edge of the escutcheon opening for the KILOCYCLE dial and is

Section 3  
ADJUSTMENT AND OPERATION

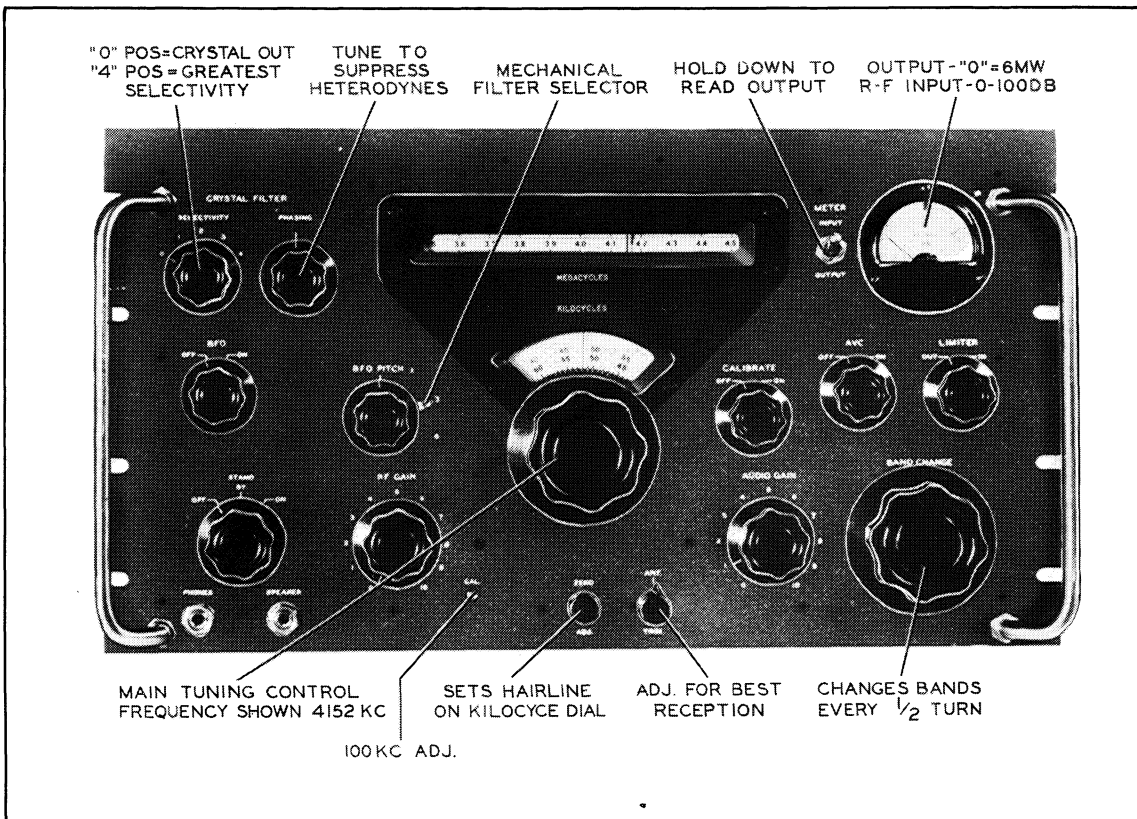

Figure 3-1. 51J-4 Operating Controls

used to log the calibrated position of the hair line on the various bands in lieu of recalibrating each time the band is used.

**NOTE**

WHEN READING THE FREQUENCY OF AN INCOMING SIGNAL, THE BFO PITCH CONTROL MUST BE LEFT IN THE SAME POSITION AS IT WAS WHEN THE RECEIVER WAS CALIBRATED.

(h) METER INPUT-OUTPUT. - The METER switch is a momentary spring-return type toggle switch. In the normal or INPUT position the meter is connected as an S meter. In the OUTPUT position, the meter is connected in the audio output circuit as a db meter.

(i) BFO OFF-ON. - In the ON position this control turns ON the beat frequency oscillator for CW reception. In the OFF position, it grounds the screen grid of the BFO tube.

(j) BFO PITCH. - The BFO pitch control varies the frequency of the beat frequency oscillator to change the pitch of the audio tone which is produced

by combining the BFO signal with the incoming signal. A range of about  $\pm 3$  kc minimum can be obtained with this control.

(k) CALIBRATE OFF-ON. - This switch is in the cathode circuit of 100 kc crystal oscillator tube V104 and turns the 100 kc oscillator ON or OFF. For an explanation of how to use the oscillator, see paragraph (g) above.

(l) AVC OFF-ON. - This switch turns AVC ON or OFF. In most cases AVC should be ON for both AM and CW reception, but may be turned OFF for CW reception if desired.

(m) LIMITER OUT-IN. - The noise limiter is useful for both AM and CW reception. When noise is not a problem, turn the LIMITER to OFF, as the distortion will be less in this position. When noise of the impulse type is being received, turn the LIMITER to ON. Adjustment of RF and AF gain controls is necessary for best CW noise limiting.

(n) CRYSTAL FILTER.

SELECTIVITY. - In position 0 of this control, the crystal filter is not used and selectivity is determined by the receiver's tuned circuits alone. In position 1 through 4, the crystal filter is in the

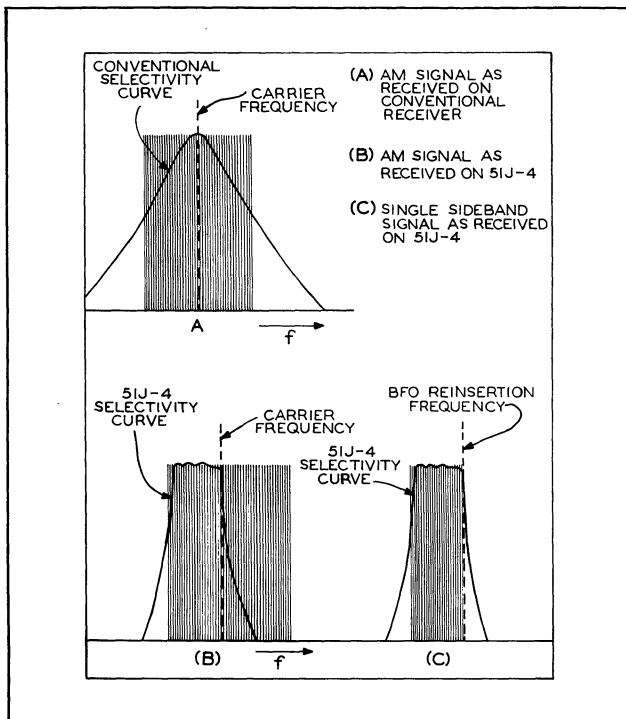

Figure 3-2. Tuning (A) a Conventional Receiver; (B) and (C) the 51J-4 using the 3KC Mechanical Filter

circuit, the selectivity being increased as position 4 is approached. Position 4 gives a bandwidth of about 200 cps at 6 db down.

**PHASING.** - The PHASING control is used to reject unwanted heterodynes. When positioned on the panel mark, the control is properly set for crystal phasing with no rejection notch. If a high frequency heterodyne is interfering with reception, move the control back and forth near the panel mark until the heterodyne is attenuated. If the heterodyne is of lower frequency, move the control farther to left or right of the panel mark. This control will attenuate heterodynes ranging from 1 to 3 kc.

(o) **METER.** - The tuning meter is calibrated in 20, 40, 60, 80 and 100 db above AVC threshold when reading r-f input. When reading audio output, the meter is calibrated from -10 to +6 db, zero reference being 6 milliwatts into a 500 ohm load.

(p) **CAL.** - If supreme accuracy is desired, the frequency of the 100 kc oscillator should be checked against WWV or some other station whose frequency is known to be extremely accurate. This oscillator frequency may be varied through small limits by turning the CAL control with a screw driver. Additional range can be obtained by turning C169, located just behind the 100 kc crystal.

(q) **FILTER SELECTOR.** - If the receiver is equipped with the complete complement of three mechanical filters, position 1 selects the 1.4 kc filter, position 3 selects the 3.1 kc filter and position 6 selects the 6 kc filter.

### 3.2.2. TUNING AM SIGNALS.

Conventional tuning is employed when using the 6 kc mechanical filter, however, when using the 3 kc filter, the tuning techniques differ somewhat. Because of the flat top and almost vertical sides of the pass band of the 3 kc filter it is possible to tune either sideband of an AM station and reject the opposite sideband. Tuning "on the nose" results in loss of the high frequency audio components with, in most cases, a loss of intelligibility. Select the sideband that contains the least objectionable adjacent channel interference. See figure 3-2(B). When the 3 kc filter is employed, use the following procedure to tune AM signals:

(a) Set up for AM reception: Power ON; operate BAND CHANGE switch to desired band; BFO to OFF; LIMITER to OUT; selectivity to O; AVC to ON; select 3 kc mechanical filter; RF GAIN maximum-use AUDIO GAIN for volume control.

(b) Tune in AM station - move dial slowly.

(c) Adjust ANT. TRIM for maximum "S" meter reading - (one setting for each new band usually sufficient).

(d) Tune toward one side of the carrier being received until "S" meter reading drops sharply. Then carefully tune into the signal again until the "S" meter reading increases to its former value and the modulation is readable. The receiver is now tuned to one sideband plus the carrier of the AM station. If heterodyne interference is strong, tune to the other side of the signal and listen to the opposite sideband.

(e) If noise is severe, turn the LIMITER switch to IN.

(f) If heterodyne interference is bad on both sidebands, tune to the better sideband and turn the SELECTIVITY control to 1. Operate the CRYSTAL FILTER PHASING control over its entire range (90° either side of center position) to find the position at which the heterodyne is weakest. With any crystal filter there are some frequencies that cannot be phased out. In the 51J-4 these occur at between 800 and 1200 cps. Generally speaking, turning the SELECTIVITY control any higher in AM reception

Section 3  
ADJUSTMENT AND OPERATION

will not give an over-all gain in results because of the loss in audio frequencies.

3.2.3. TUNING SINGLE-SIDEBAND SIGNALS.

The 51J-4 is used for single sideband reception in much the same manner as is any other communications receiver. The transmitted signals carrier must be reinserted at the receiver, of course, and in the 51J-4, this is done by turning on the BFO. Before attempting to receive single sideband signals, calibrate the BFO following the procedure in paragraph (a) below. After the BFO has once been calibrated it will only be necessary to recalibrate as component aging or extreme temperature variations cause the BFO frequency to shift.

(a) Calibrating the BFO. Calibrating the BFO makes it possible to set the receiver up for single sideband reception with minimum delay thereafter. It, in effect, establishes the correct point in the receivers passband at which the carrier is being reinserted. See figure 3-2(B). We calibrate for both upper and lower sideband operation.

(1) Set up for AM reception but do not turn on the crystal filter. (POWER ON; operate BAND CHANGE to desired band; BFO to OFF; AVC to ON; AUDIO GAIN maximum - use RF GAIN for volume control; use 3 kc filter).

(2) Turn the CALIBRATE switch to ON and tune to the exact center of the signal (the "S" meter is helpful here). Turn on the BFO. If the BFO is correctly adjusted the zero beat should occur at or very near the center position of the BFO PITCH knob. Turn the BFO off.

(3) It has been determined that for best results, the reinserted carrier (BFO signal) should be placed 18 to 20 db down on the filter skirt. The point to set the BFO can be found by the following method: Tune in a signal of approximately S-9 either from the calibrator at one of the calibrator check points or from a signal generator. Tune the receiver dial below the signal until the S-meter has dropped 3-S units (18 db). Turn the BFO switch to ON. Increase the audio gain and decrease the RF gain to prevent overloading. Zero beat the bfo with the front panel BFO PITCH control. Note the position of the BFO PITCH knob.

(4) Return the receiver controls for AM reception, tune the receiver dial above the input signal until the S-meter shows a decrease of 3-S units on this side of the filter curve. Again return to CW reception, zero beat the BFO PITCH and note the knob position.

(b) Set up for single-sideband reception: Power ON; operate BAND CHANGE to desired band; BFO to ON; LIMITER to OUT; SELECTIVITY to O; AVC to OFF; use 3 kc filter maximum - use RF GAIN for volume control.

(c) Adjust ANT. TRIM for maximum background noise.

(d) Tune to S.S.S.C. station with RF GAIN at low setting to prevent overload. (There is no avc now.)

(e) Turn the BFO PITCH control counterclockwise to the left hand position mark as determined in step (a).

(f) Very carefully adjust the main tuning dial until the S.S.S.C. signal becomes readable. This may take considerable patience the first few times because tuning to an S.S.S.C. station is more critical than tuning for AM signals. Do not adjust the BFO PITCH after it is once set - rather, make all tuning adjustments with the main tuning dial. If the signals cannot be made readable, set the BFO PITCH to the clockwise mark and again carefully adjust the main tuning dial.

(g) Advance the RF GAIN to suit.

(h) If heterodyne interference is severe, turn the SELECTIVITY control position 1 and adjust the crystal filter PHASING control to "notch out" the interfering signal, as described in paragraph 3.2.1. (n), of this section.

3.2.4. TUNING CW SIGNALS.

The extreme selectivity of the 51J-4 Receiver makes single-signal reception an inherent feature of the set. However, because of the selectivity, careful tuning and special techniques are in order. Best single-signal reception is with the BFO PITCH set to produce a 1000 cps peak note when using the 3 kc filter.

(a) Set up for CW reception: Power ON; operate BAND CHANGE to desired band; BFO to ON; SELECTIVITY to O; LIMITER to OUT; AVC to OUT; AUDIO GAIN maximum - use RF GAIN for volume control.

(b) Adjust BFO PITCH to approximately 1/4" off the index mark.

(c) Adjust ANT. TRIM for maximum background noise.

(d) Tune in a cw station. Carefully adjust the main tuning control for the loudest signal.

(e) Adjust the BFO PITCH control to the desired pitch.

(f) If interference is present try tuning to zero beat with the interference while at the same time retaining an audible beat note with the desired signal.

(g) If the results of step f. are unsatisfactory, turn the BFO PITCH control to the other side of center and repeat step f.

(h) If steps f. and g. do not produce satisfactory reception, plate the SELECTIVITY in positions 1-2-3 or 4, as required, and carefully retune the main tuning control. When greatest audio output is reached, move the PHASING control slowly out each side from center and try to phase out the interfering signal. If adjacent signals are no problem, leave the PHASING control in center position for minimum background hiss.

(i) Further selectivity can be gained by switching in the 1 kc filter on receivers so equipped. The tuning procedures are the same except that the BFO PITCH control must not be set so far out. When searching for signals it is usually better to use the 3 kc filter and have the crystal filter out, i. e. SELECTIVITY control in the O position.

#### 3.2.5. FREQUENCY MEASURING.

For AM and single-sideband reception using the 3 kc filter the 51J-4 dial reading will not necessarily correspond to the carrier frequency of the station being received. Depending upon whether the upper or lower sideband is tuned, the actual carrier frequency will be approximately 1.5 kc lower or higher than the dial reading indicates. For CW reception, if the CW station is properly tuned, the

dial reading should correspond to the carrier frequency. More accurate frequency measuring procedures are outlined below.

(a) Calibration: Frequency readings will be more accurate if the calibrator is used to calibrate the dial before frequency measurements are made. To use the calibrator, set up for CW reception (paragraph 3.2.4. (a) of this section), tune to the 100-kc point nearest the frequency to be measured, set the BFO PITCH control to center position, and turn on the calibrator. Zero beat the calibrator signal, using the main tuning control. Adjust the ZERO ADJ knob so that the dial marker lines up with zero on the KILOCYCLE dial. Turn off the calibrator.

(b) To measure the carrier frequency of an AM station, turn the SELECTIVITY control to 4, tune the station for maximum "S" meter reading, and read the frequency on the tuning dial.

### 3.3. NOTES ON MECHANICAL FILTERS.

3.3.1. GENERAL. - Certain characteristics of the mechanical filter must be considered when choosing the filter best suited for the reception conditions of each signal.

(a) Selective fading may be more noticeable when receiving AM on just one sideband. If selective fading is bad but adjacent channel interference is not, choose the 6 kc filter and tune the signal at the center of the passband.

(b) When using the 3 kc filter and one sideband for reception, there is an inherent 6 db loss in detector sensitivity due to detecting only one sideband; however, 3 db is picked up because of using a narrower bandwidth. Thus there is a net loss of 3 db in sensitivity. On weak signals it may be better to choose the 6 kc filter and tune "on the nose" except in event of adjacent channel interference, in which case the 3 kc filter may still be the best choice.